

# 圧力荷重換算表

## 500kN300ストローク 油圧ジャッキ

最低機械高	550 mm
受圧面積	95 cm <sup>2</sup>
最高使用圧力	52.6 MPa
所要油量	2.9 L
重量	約69 kg

圧力 : MPa  $\times 10.2$   $\rightarrow$  kg/cm<sup>2</sup>  
 荷重 : ton  $\times 9.8$   $\rightarrow$  kN  
 圧力[MPa] × 受圧面積[cm<sup>2</sup>] / 10 = 荷重[kN]

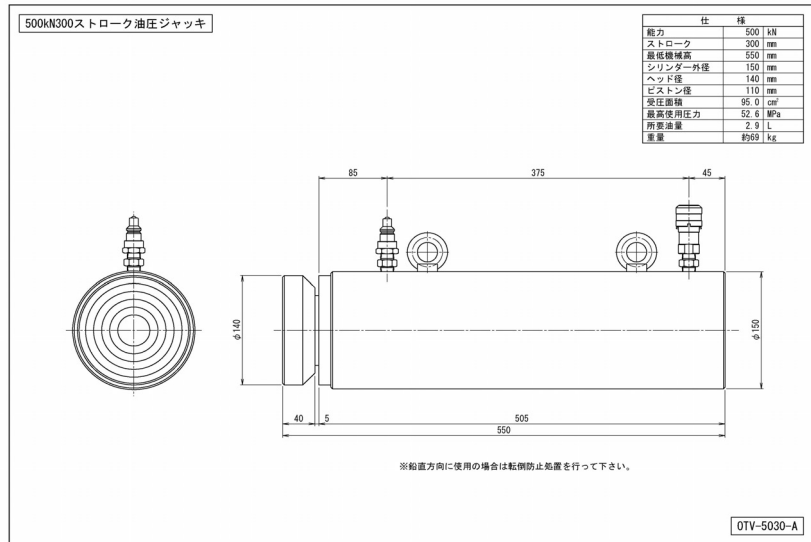

圧力		荷重	
MPa	kg/cm <sup>2</sup>	kN	ton
1	10	10	1.0
2	20	19	1.9
3	31	29	2.9
4	41	38	3.9
5	51	48	4.8
6	61	57	5.8
7	71	67	6.8
8	82	76	7.8
9	92	86	8.7
10	102	95	9.7
11	112	105	10.7
12	122	114	11.6
13	133	124	12.6
14	143	133	13.6
15	153	143	14.5
16	163	152	15.5
17	173	162	16.5
18	184	171	17.4
19	194	181	18.4
20	204	190	19.4

圧力		荷重	
MPa	kg/cm <sup>2</sup>	kN	ton
21	214	200	20.3
22	224	209	21.3
23	235	219	22.3
24	245	228	23.3
25	255	238	24.2
26	265	247	25.2
27	275	257	26.2
28	286	266	27.1
29	296	276	28.1
30	306	285	29.1
31	316	295	30.0
32	326	304	31.0
33	337	314	32.0
34	347	323	32.9
35	357	333	33.9
36	367	342	34.9
37	377	352	35.9
38	388	361	36.8
39	398	371	37.8
40	408	380	38.8

圧力		荷重	
MPa	kg/cm <sup>2</sup>	kN	ton
41	418	390	39.7
42	428	399	40.7
43	439	409	41.7
44	449	418	42.6
45	459	428	43.6
46	469	437	44.6
47	479	447	45.5
48	490	456	46.5
49	500	466	47.5
50	510	475	48.5
51	520	485	49.4
52	530	494	50.4
52.6	537	500	51.0