

圧力荷重換算表

1500kN300ストローク 油圧ジャッキ

最低機械高	540 mm
受圧面積	254.5 cm ²
最高使用圧力	58.9 MPa
所要油量	7.6 L
重量	約185 kg

圧力 : MPa $\times 10.2$ kg/cm²
 荷重 : ton $\times 9.8$ kN
 圧力[MPa] × 受圧面積[cm²] / 10 = 荷重[kN]

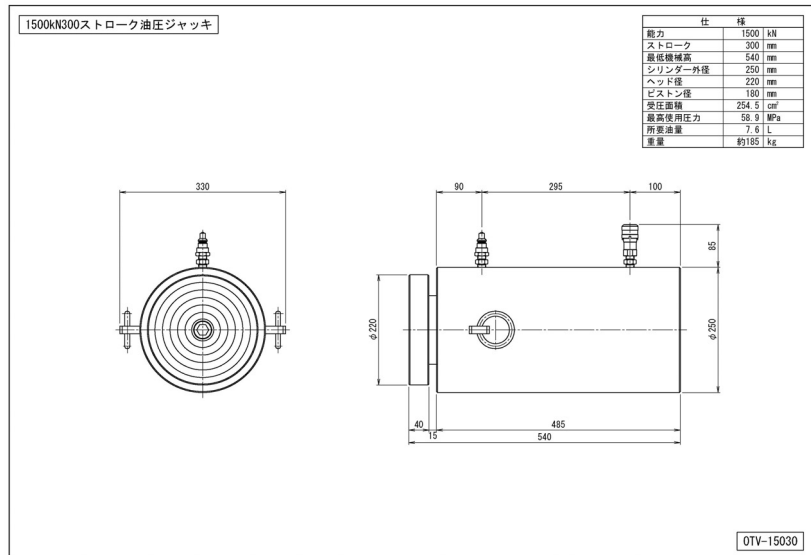

圧力		荷重	
MPa	kg/cm ²	kN	ton
1	10	25	2.6
2	20	51	5.2
3	31	76	7.8
4	41	102	10.4
5	51	127	13.0
6	61	153	15.6
7	71	178	18.2
8	82	204	20.8
9	92	229	23.4
10	102	255	26.0
11	112	280	28.6
12	122	305	31.2
13	133	331	33.7
14	143	356	36.3
15	153	382	38.9
16	163	407	41.5
17	173	433	44.1
18	184	458	46.7
19	194	484	49.3
20	204	509	51.9

圧力		荷重	
MPa	kg/cm ²	kN	ton
21	214	534	54.5
22	224	560	57.1
23	235	585	59.7
24	245	611	62.3
25	255	636	64.9
26	265	662	67.5
27	275	687	70.1
28	286	713	72.7
29	296	738	75.3
30	306	764	77.9
31	316	789	80.5
32	326	814	83.1
33	337	840	85.7
34	347	865	88.3
35	357	891	90.9
36	367	916	93.5
37	377	942	96.0
38	388	967	98.6
39	398	993	101.2
40	408	1018	103.8

圧力		荷重	
MPa	kg/cm ²	kN	ton
41	418	1043	106.4
42	428	1069	109.0
43	439	1094	111.6
44	449	1120	114.2
45	459	1145	116.8
46	469	1171	119.4
47	479	1196	122.0
48	490	1222	124.6
49	500	1247	127.2
50	510	1273	129.8
51	520	1298	132.4
52	530	1323	135.0
53	541	1349	137.6
54	551	1374	140.2
55	561	1400	142.8
56	571	1425	145.4
57	581	1451	148.0
58	592	1476	150.6
59	602	1502	153.2