

圧力荷重換算表

700kN50ストロークCH型

油圧ジャッキ

最低機械高	195 mm
ホール径	52 mm
受圧面積	104.7 cm ²
最高使用圧力	66.9 MPa
所要油量	0.52 L
重量	約30 kg

圧力 : MPa $\times 10.2$ kg/cm²
 荷重 : ton $\times 9.8$ kN
 圧力[MPa] \times 受圧面積[cm²]/10=荷重[kN]

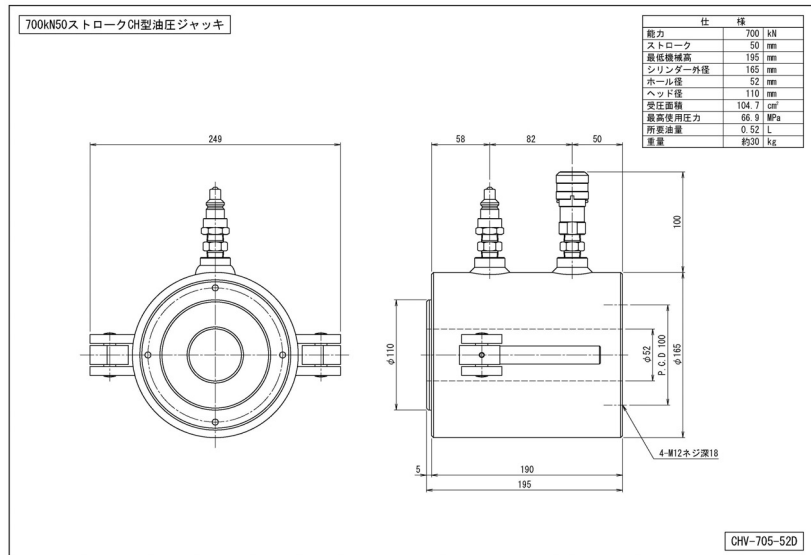

圧力		荷重	
MPa	kg/cm ²	kN	ton
1	10	10	1.1
2	20	21	2.1
3	31	31	3.2
4	41	42	4.3
5	51	52	5.3
6	61	63	6.4
7	71	73	7.5
8	82	84	8.5
9	92	94	9.6
10	102	105	10.7
11	112	115	11.7
12	122	126	12.8
13	133	136	13.9
14	143	147	15.0
15	153	157	16.0
16	163	168	17.1
17	173	178	18.2
18	184	188	19.2
19	194	199	20.3
20	204	209	21.4

圧力		荷重	
MPa	kg/cm ²	kN	ton
21	214	220	22.4
22	224	230	23.5
23	235	241	24.6
24	245	251	25.6
25	255	262	26.7
26	265	272	27.8
27	275	283	28.8
28	286	293	29.9
29	296	304	31.0
30	306	314	32.0
31	316	325	33.1
32	326	335	34.2
33	337	346	35.2
34	347	356	36.3
35	357	366	37.4
36	367	377	38.4
37	377	387	39.5
38	388	398	40.6
39	398	408	41.6
40	408	419	42.7

圧力		荷重	
MPa	kg/cm ²	kN	ton
41	418	429	43.8
42	428	440	44.9
43	439	450	45.9
44	449	461	47.0
45	459	471	48.1
46	469	482	49.1
47	479	492	50.2
48	490	503	51.3
49	500	513	52.3
50	510	524	53.4
51	520	534	54.5
52	530	544	55.5
53	541	555	56.6
54	551	565	57.7
55	561	576	58.7
56	571	586	59.8
57	581	597	60.9
58	592	607	61.9
59	602	618	63.0
60	612	628	64.1
61	622	639	65.1
62	632	649	66.2
63	643	660	67.3
64	653	670	68.3
65	663	681	69.4
66	673	691	70.5
66.9	682	700	71.4