

# 圧力荷重換算表

## 1500kN100ストロークCH型 油圧ジャッキ

最低機械高	305 mm
ホール径	95 mm
受圧面積	247.4 cm <sup>2</sup>
最高使用圧力	60.6 MPa
所要油量	2.5 L
重量	約120 kg

圧力 : MPa  $\times 10.2$  kg/cm<sup>2</sup>  
 荷重 : ton  $\times 9.8$  kN  
 圧力[MPa]  $\times$  受圧面積[cm<sup>2</sup>]/10=荷重[kN]

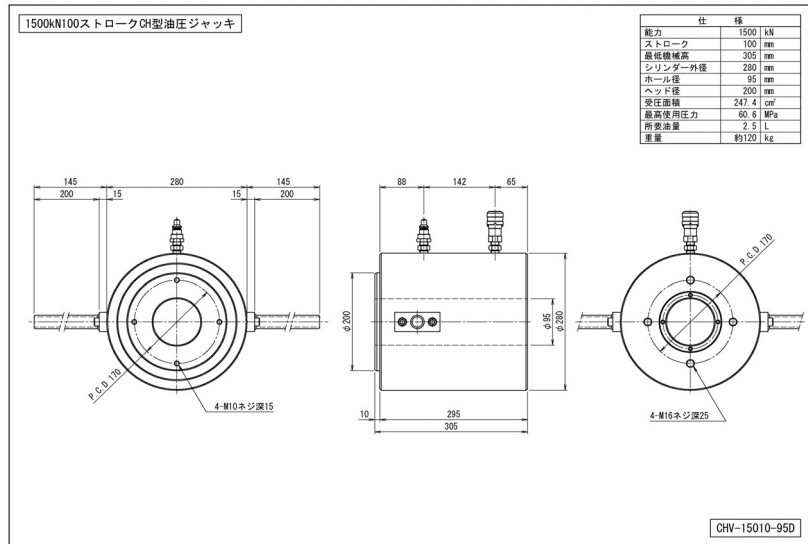

圧力		荷重	
MPa	kg/cm <sup>2</sup>	kN	ton
1	10	25	2.5
2	20	49	5.0
3	31	74	7.6
4	41	99	10.1
5	51	124	12.6
6	61	148	15.1
7	71	173	17.7
8	82	198	20.2
9	92	223	22.7
10	102	247	25.2
11	112	272	27.8
12	122	297	30.3
13	133	322	32.8
14	143	346	35.3
15	153	371	37.9
16	163	396	40.4
17	173	421	42.9
18	184	445	45.4
19	194	470	47.9
20	204	495	50.5

圧力		荷重	
MPa	kg/cm <sup>2</sup>	kN	ton
21	214	520	53.0
22	224	544	55.5
23	235	569	58.0
24	245	594	60.6
25	255	619	63.1
26	265	643	65.6
27	275	668	68.1
28	286	693	70.7
29	296	717	73.2
30	306	742	75.7
31	316	767	78.2
32	326	792	80.8
33	337	816	83.3
34	347	841	85.8
35	357	866	88.3
36	367	891	90.8
37	377	915	93.4
38	388	940	95.9
39	398	965	98.4
40	408	990	100.9

圧力		荷重	
MPa	kg/cm <sup>2</sup>	kN	ton
41	418	1014	103.5
42	428	1039	106.0
43	439	1064	108.5
44	449	1089	111.0
45	459	1113	113.6
46	469	1138	116.1
47	479	1163	118.6
48	490	1188	121.1
49	500	1212	123.7
50	510	1237	126.2
51	520	1262	128.7
52	530	1286	131.2
53	541	1311	133.7
54	551	1336	136.3
55	561	1361	138.8
56	571	1385	141.3
57	581	1410	143.8
58	592	1435	146.4
59	602	1460	148.9
60	612	1484	151.4
60.6	618	1499	152.9