

圧力荷重換算表

4000kN1500ストロークCH型 油圧ジャッキ

最低機械高	2210 mm
ホール径	152 mm
受圧面積	623 cm ²
最高使用圧力	64.2 MPa
所要油量	93.5 L
重量	約3100 kg

圧力 : MPa $\times 10.2$ kg/cm²

荷重 : ton $\times 9.8$ kN

圧力[MPa] \times 受圧面積[cm²]/10=荷重[kN]

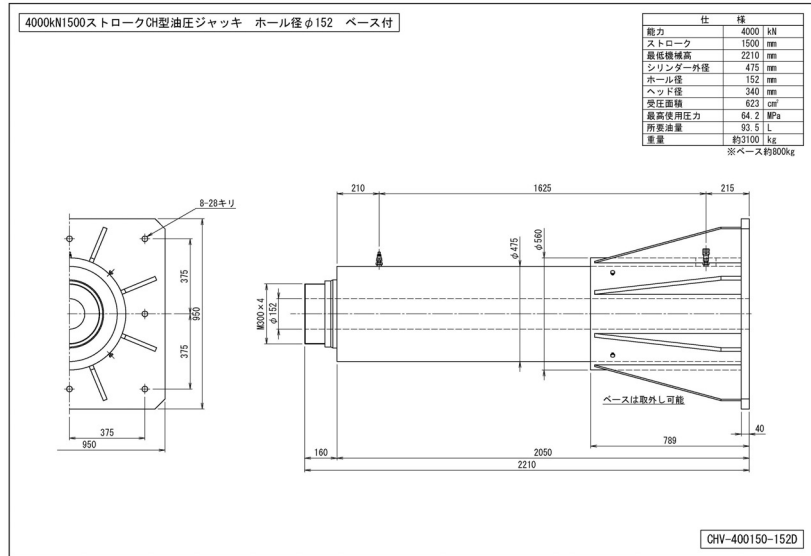

圧力		荷重	
MPa	kg/cm ²	kN	ton
1	10	62	6.4
2	20	125	12.7
3	31	187	19.1
4	41	249	25.4
5	51	312	31.8
6	61	374	38.1
7	71	436	44.5
8	82	498	50.8
9	92	561	57.2
10	102	623	63.5
11	112	685	69.9
12	122	748	76.3
13	133	810	82.6
14	143	872	89.0
15	153	935	95.3
16	163	997	101.7
17	173	1059	108.0
18	184	1121	114.4
19	194	1184	120.7
20	204	1246	127.1

圧力		荷重	
MPa	kg/cm ²	kN	ton
21	214	1308	133.4
22	224	1371	139.8
23	235	1433	146.2
24	245	1495	152.5
25	255	1558	158.9
26	265	1620	165.2
27	275	1682	171.6
28	286	1744	177.9
29	296	1807	184.3
30	306	1869	190.6
31	316	1931	197.0
32	326	1994	203.3
33	337	2056	209.7
34	347	2118	216.1
35	357	2181	222.4
36	367	2243	228.8
37	377	2305	235.1
38	388	2367	241.5
39	398	2430	247.8
40	408	2492	254.2

圧力		荷重	
MPa	kg/cm ²	kN	ton
41	418	2554	260.5
42	428	2617	266.9
43	439	2679	273.2
44	449	2741	279.6
45	459	2804	286.0
46	469	2866	292.3
47	479	2928	298.7
48	490	2990	305.0
49	500	3053	311.4
50	510	3115	317.7
51	520	3177	324.1
52	530	3240	330.4
53	541	3302	336.8
54	551	3364	343.1
55	561	3427	349.5
56	571	3489	355.9
57	581	3551	362.2
58	592	3613	368.6
59	602	3676	374.9
60	612	3738	381.3
61	622	3800	387.6
62	632	3863	394.0
63	643	3925	400.3
64	653	3987	406.7
64.2	655	4000	408.0