

# 圧力荷重換算表

## 500kN200ストローク 試験用油圧ジャッキ

最低機械高	375 mm
受圧面積	86.59 cm <sup>2</sup>
最高使用圧力	57.7 MPa
所要油量	1.7 L
重量	約38 kg

圧力 : MPa  $\times 10.2$   $\rightarrow$  kg/cm<sup>2</sup>  
 荷重 : ton  $\times 9.8$   $\rightarrow$  kN  
 圧力[MPa] × 受圧面積[cm<sup>2</sup>] / 10 = 荷重[kN]

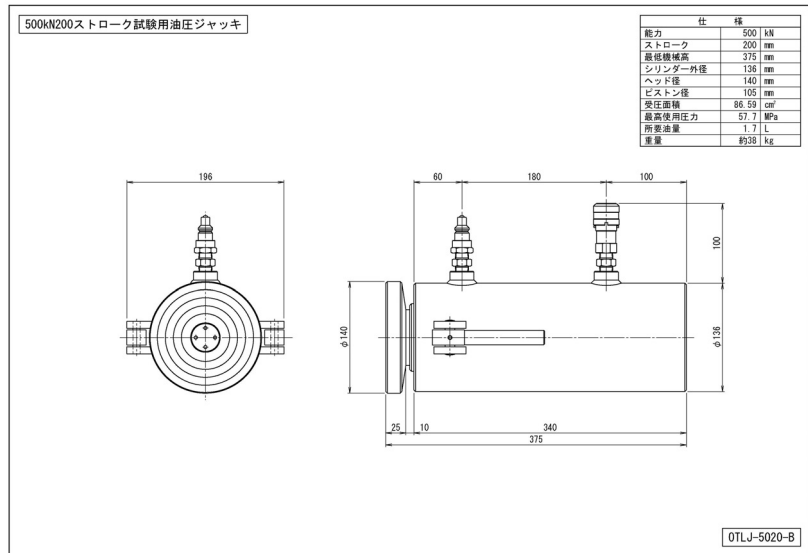

圧力		荷重	
MPa	kg/cm <sup>2</sup>	kN	ton
1	10	9	0.9
2	20	17	1.8
3	31	26	2.6
4	41	35	3.5
5	51	43	4.4
6	61	52	5.3
7	71	61	6.2
8	82	69	7.1
9	92	78	7.9
10	102	87	8.8
11	112	95	9.7
12	122	104	10.6
13	133	113	11.5
14	143	121	12.4
15	153	130	13.2
16	163	139	14.1
17	173	147	15.0
18	184	156	15.9
19	194	165	16.8
20	204	173	17.7

圧力		荷重	
MPa	kg/cm <sup>2</sup>	kN	ton
21	214	182	18.5
22	224	190	19.4
23	235	199	20.3
24	245	208	21.2
25	255	216	22.1
26	265	225	23.0
27	275	234	23.8
28	286	242	24.7
29	296	251	25.6
30	306	260	26.5
31	316	268	27.4
32	326	277	28.3
33	337	286	29.1
34	347	294	30.0
35	357	303	30.9
36	367	312	31.8
37	377	320	32.7
38	388	329	33.6
39	398	338	34.4
40	408	346	35.3

圧力		荷重	
MPa	kg/cm <sup>2</sup>	kN	ton
41	418	355	36.2
42	428	364	37.1
43	439	372	38.0
44	449	381	38.9
45	459	390	39.7
46	469	398	40.6
47	479	407	41.5
48	490	416	42.4
49	500	424	43.3
50	510	433	44.2
51	520	442	45.0
52	530	450	45.9
53	541	459	46.8
54	551	468	47.7
55	561	476	48.6
56	571	485	49.5
57	581	494	50.3
57.7	589	500	51.0