

圧力荷重換算表

1000kN30ストローク 補修用油圧ジャッキ

最低機械高	135 mm
受圧面積	149.2 cm ²
最高使用圧力	67.0 MPa
所要油量	0.45 L
重量	約33 kg

圧力 : MPa $\times 10.2$ \rightarrow kg/cm²
 荷重 : ton $\times 9.8$ \rightarrow kN
 圧力[MPa] × 受圧面積[cm²]/10=荷重[kN]

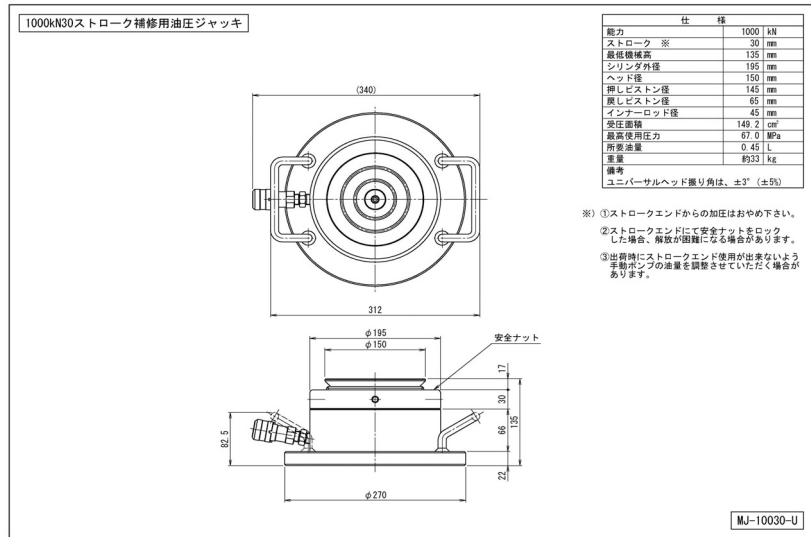

圧力		荷重	
MPa	kg/cm ²	kN	ton
1	10	15	1.5
2	20	30	3.0
3	31	45	4.6
4	41	60	6.1
5	51	75	7.6
6	61	90	9.1
7	71	104	10.7
8	82	119	12.2
9	92	134	13.7
10	102	149	15.2
11	112	164	16.7
12	122	179	18.3
13	133	194	19.8
14	143	209	21.3
15	153	224	22.8
16	163	239	24.3
17	173	254	25.9
18	184	269	27.4
19	194	283	28.9
20	204	298	30.4

圧力		荷重	
MPa	kg/cm ²	kN	ton
21	214	313	32.0
22	224	328	33.5
23	235	343	35.0
24	245	358	36.5
25	255	373	38.0
26	265	388	39.6
27	275	403	41.1
28	286	418	42.6
29	296	433	44.1
30	306	448	45.7
31	316	463	47.2
32	326	477	48.7
33	337	492	50.2
34	347	507	51.7
35	357	522	53.3
36	367	537	54.8
37	377	552	56.3
38	388	567	57.8
39	398	582	59.4
40	408	597	60.9

圧力		荷重	
MPa	kg/cm ²	kN	ton
41	418	612	62.4
42	428	627	63.9
43	439	642	65.4
44	449	656	67.0
45	459	671	68.5
46	469	686	70.0
47	479	701	71.5
48	490	716	73.0
49	500	731	74.6
50	510	746	76.1
51	520	761	77.6
52	530	776	79.1
53	541	791	80.7
54	551	806	82.2
55	561	821	83.7
56	571	836	85.2
57	581	850	86.7
58	592	865	88.3
59	602	880	89.8
60	612	895	91.3
61	622	910	92.8
62	632	925	94.4
63	643	940	95.9
64	653	955	97.4
65	663	970	98.9
66	673	985	100.4
67	683	1000	102.0