

圧力荷重換算表

5000kN75ストローク 補修用油圧ジャッキ

最低機械高	360 mm
受圧面積	743 cm ²
最高使用圧力	67.3 MPa
所要油量	5.6 L
重量	約342 kg

圧力 : MPa $\times 10.2$ \rightarrow kg/cm²
 荷重 : ton $\times 9.8$ \rightarrow kN
 圧力[MPa] \times 受圧面積[cm²]/10=荷重[kN]

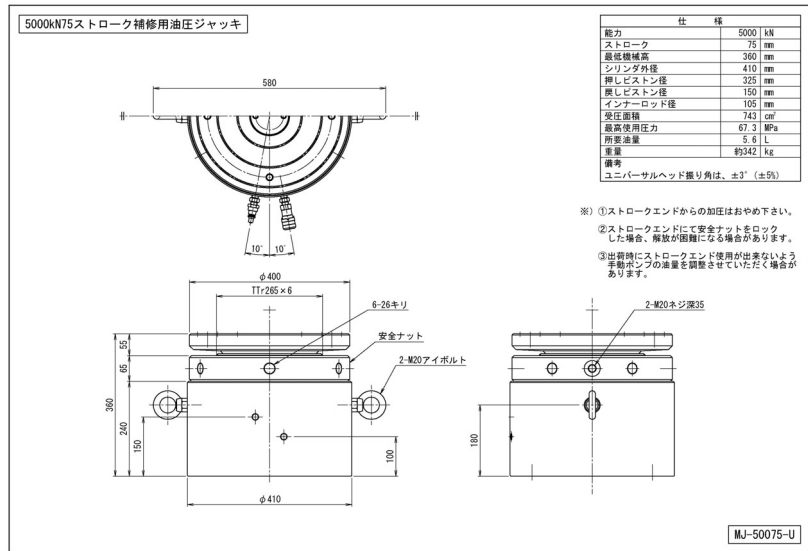

圧力		荷重	
MPa	kg/cm ²	kN	ton
1	10	74	7.6
2	20	149	15.2
3	31	223	22.7
4	41	297	30.3
5	51	372	37.9
6	61	446	45.5
7	71	520	53.1
8	82	594	60.6
9	92	669	68.2
10	102	743	75.8
11	112	817	83.4
12	122	892	90.9
13	133	966	98.5
14	143	1040	106.1
15	153	1115	113.7
16	163	1189	121.3
17	173	1263	128.8
18	184	1337	136.4
19	194	1412	144.0
20	204	1486	151.6

圧力		荷重	
MPa	kg/cm ²	kN	ton
21	214	1560	159.2
22	224	1635	166.7
23	235	1709	174.3
24	245	1783	181.9
25	255	1858	189.5
26	265	1932	197.0
27	275	2006	204.6
28	286	2080	212.2
29	296	2155	219.8
30	306	2229	227.4
31	316	2303	234.9
32	326	2378	242.5
33	337	2452	250.1
34	347	2526	257.7
35	357	2601	265.3
36	367	2675	272.8
37	377	2749	280.4
38	388	2823	288.0
39	398	2898	295.6
40	408	2972	303.1

圧力		荷重	
MPa	kg/cm ²	kN	ton
41	418	3046	310.7
42	428	3121	318.3
43	439	3195	325.9
44	449	3269	333.5
45	459	3344	341.0
46	469	3418	348.6
47	479	3492	356.2
48	490	3566	363.8
49	500	3641	371.4
50	510	3715	378.9
51	520	3789	386.5
52	530	3864	394.1
53	541	3938	401.7
54	551	4012	409.2
55	561	4087	416.8
56	571	4161	424.4
57	581	4235	432.0
58	592	4309	439.6
59	602	4384	447.1
60	612	4458	454.7
61	622	4532	462.3
62	632	4607	469.9
63	643	4681	477.5
64	653	4755	485.0
65	663	4830	492.6
66	673	4904	500.2
67	683	4978	507.8
67.3	686	5000	510.0