

圧力荷重換算表

3000kN 送り台

受圧面積 3000kNジャッキ 490.9cm²
 受圧面積 推進ジャッキ 78.5cm²
 最高使用圧力 3000kNジャッキ:61.1MPa
 最高使用圧力 推進ジャッキ:63.7MPa
 総重量 325 kg

圧力 : MPa $\times 10.2$ \rightarrow kg/cm²
 荷重 : ton $\times 9.8$ \rightarrow kN
 圧力[MPa] \times 受圧面積[cm²]/10=荷重[kN]

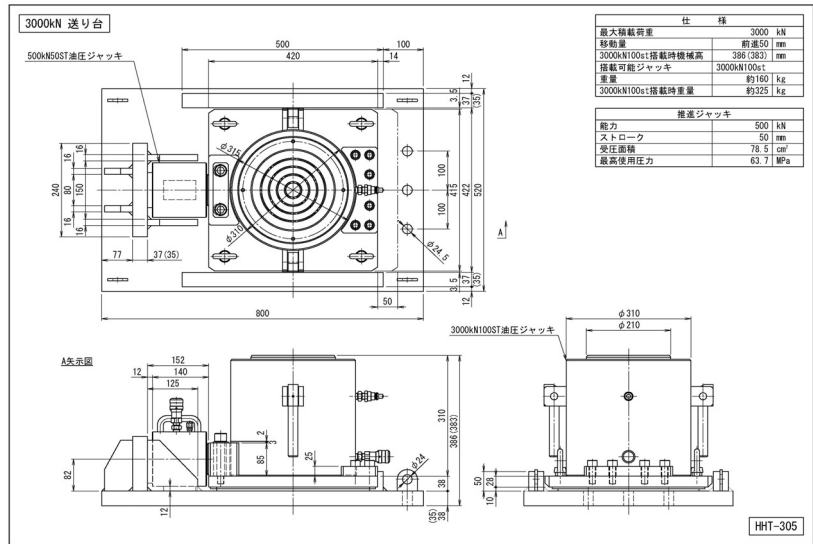

荷重 (3000kNジャッキ)

圧力		荷重	
MPa	kg/cm ²	kN	ton
1	10	49	5.0
2	20	98	10.0
3	31	147	15.0
4	41	196	20.0
5	51	245	25.0
6	61	295	30.0
7	71	344	35.1
8	82	393	40.1
9	92	442	45.1
10	102	491	50.1
11	112	540	55.1
12	122	589	60.1
13	133	638	65.1
14	143	687	70.1
15	153	736	75.1
16	163	785	80.1
17	173	835	85.1
18	184	884	90.1
19	194	933	95.1
20	204	982	100.1
21	214	1031	105.2
22	224	1080	110.2
23	235	1129	115.2
24	245	1178	120.2
25	255	1227	125.2
26	265	1276	130.2
27	275	1325	135.2
28	286	1375	140.2
29	296	1424	145.2
30	306	1473	150.2

推進力 (500kNジャッキ)

圧力		荷重	
MPa	kg/cm ²	kN	ton
31	316	1522	155.2
32	326	1571	160.2
33	337	1620	165.2
34	347	1669	170.2
35	357	1718	175.3
36	367	1767	180.3
37	377	1816	185.3
38	388	1865	190.3
39	398	1915	195.3
40	408	1964	200.3
41	418	2013	205.3
42	428	2062	210.3
43	439	2111	215.3
44	449	2160	220.3
45	459	2209	225.3
46	469	2258	230.3
47	479	2307	235.3
48	490	2356	240.3
49	500	2405	245.4
50	510	2455	250.4
51	520	2504	255.4
52	530	2553	260.4
53	541	2602	265.4
54	551	2651	270.4
55	561	2700	275.4
56	571	2749	280.4
57	581	2798	285.4
58	592	2847	290.4
59	602	2896	295.4
60	612	2945	300.4
61	622	2994	305.4
61.1	623	2999	305.9

圧力		推進力	
MPa	kg/cm ²	kN	ton
2	20	16	1.6
4	41	31	3.2
6	61	47	4.8
8	82	63	6.4
10	102	79	8.0
12	122	94	9.6
14	143	110	11.2
16	163	126	12.8
18	184	141	14.4
20	204	157	16.0
22	224	173	17.6
24	245	188	19.2
26	265	204	20.8
28	286	220	22.4
30	306	236	24.0
32	326	251	25.6
34	347	267	27.2
36	367	283	28.8
38	388	298	30.4
40	408	314	32.0
42	428	330	33.6
44	449	345	35.2
46	469	361	36.8
48	490	377	38.4
50	510	393	40.0
52	530	408	41.6
54	551	424	43.2
56	571	440	44.8
58	592	455	46.4
60	612	471	48.0
62	632	487	49.6
63.7	650	500	51.0